

MCDN-030-TBNS

DOUBLE ACTING
TWO FLANGED PORTS

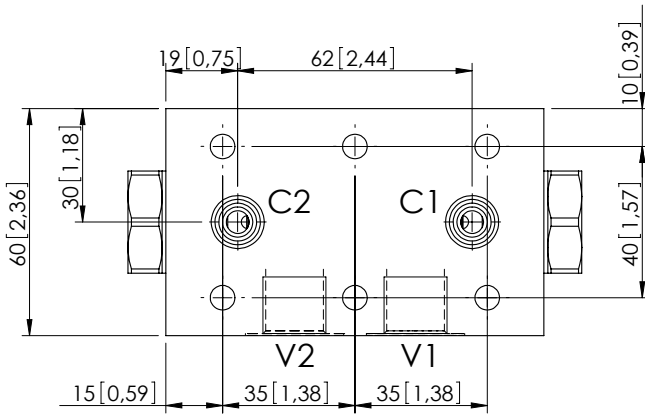

Dimensions: mm [inches]

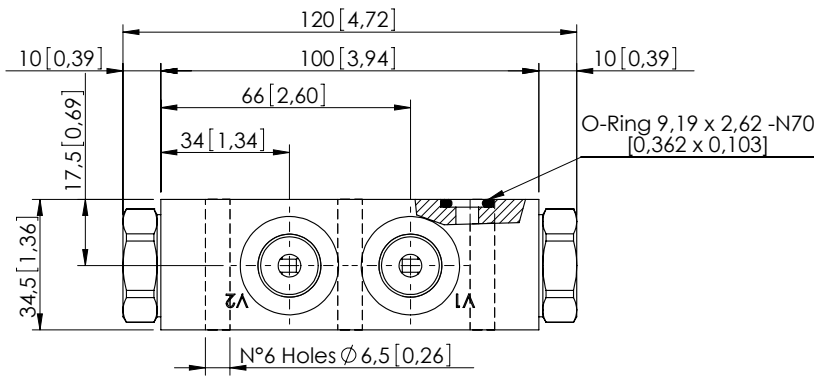
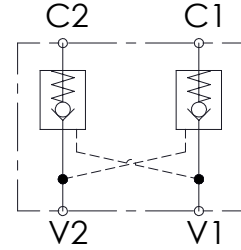

SPECIFICATIONS

Max. operating pressure:	350 bar (5000 psi)
Rated flow:	30 l/min (8 gpm)
Manifold:	Aluminium
Weight:	0,67 kg (1,48 lbs)
Contamination class to ISO 4406:	See technical spec.
MTF _d :	150 years

NOTES

CURVES

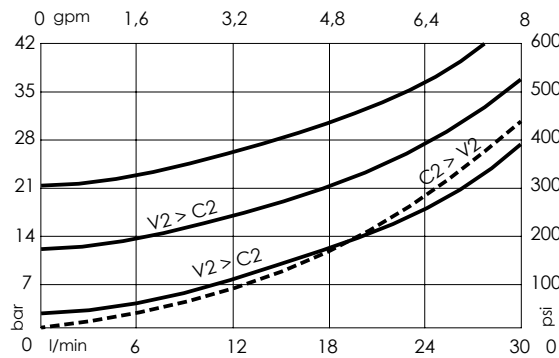

ORDERING CODES

Quick code	Description	Main ports size	Pilot ratio	Cracking pressure	O-ring on pilot piston
MC000005	MCDN-030-TBNS-07-G38-N001	V1,V2:G 3/8" C1,C2:Ø 6	7:1	1 bar (15 psi)	NO
MC000012	MCDN-030-TBNS-07-G38-N005	V1,V2:G 3/8" C1,C2:Ø 6	7:1	5 bar (75 psi)	NO
MC000020	MCDN-030-TBNC-07-G38-N005	V1,V2:G 3/8" C1,C2:Ø 6	7:1	5 bar (75 psi)	YES
MC000092	MCDN-030-LBNS-07-G38-N009	V1,V2:G 3/8" C1,C2:Ø 6	7:1	9 bar (125 psi)	NO
MC000195	MCDN-030-LBNC-07-G38-N009	V1,V2:G 3/8" C1,C2:Ø 6	7:1	9 bar (125 psi)	YES