

CDPN-030-PANR

INTEGRAL PILOT
PISTON

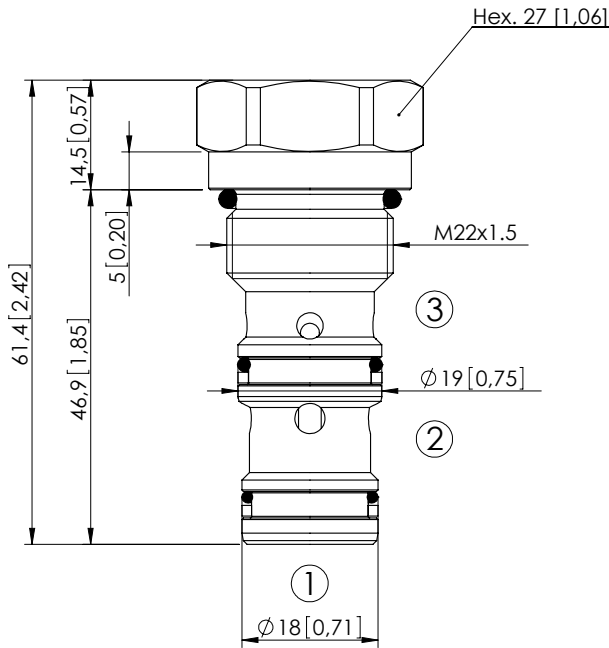

Dimensions: mm [inches]

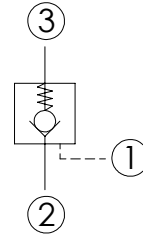

SPECIFICATIONS

Max. operating pressure:	350 bar (5000 psi)
Rated flow:	30 l/min (8 gpm)
Cavity:	VP000314
Weight:	0,1 kg (0,22 lbs)
Pilot ratio:	4 : 1
Contamination class to ISO 4406:	See technical spec.
Seal kit:	RC700314
Installation torque:	55 - 62 Nm (41 - 46 ft-lb)
MTF _a :	150 years

NOTES

CURVES

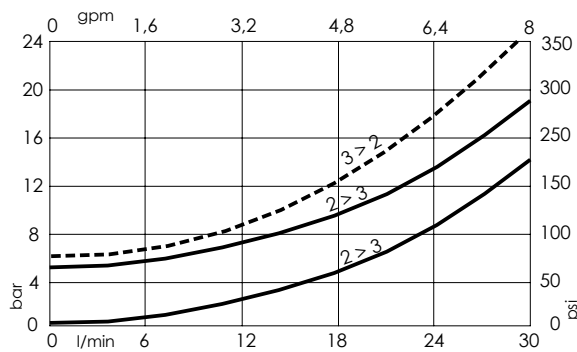

ORDERING CODES

Quick code	Description	Cracking pressure	O-ring on pilot piston
CD000186	CDPN-030-PANR-04-314-N005	5 bar (75 psi)	YES
CD000235	CDPN-030-PANM-04-314-N001	1 bar (15 psi)	NO