

CHECK VALVE

CDVN-050-PSNR

POPPET TYPE

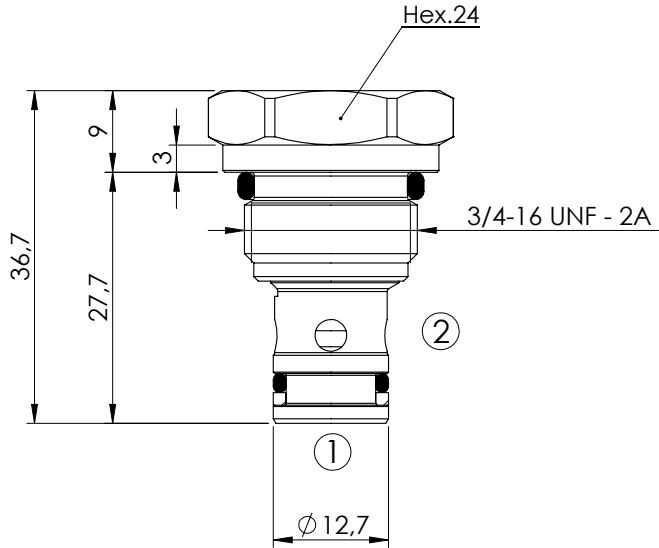
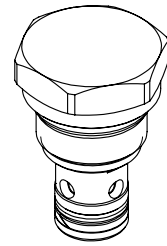

SPECIFICATIONS

Max. operating pressure:	350 bar
Rated flow:	50 l/min
Cavity:	SAE-08-2N
Weight:	0,06 kg

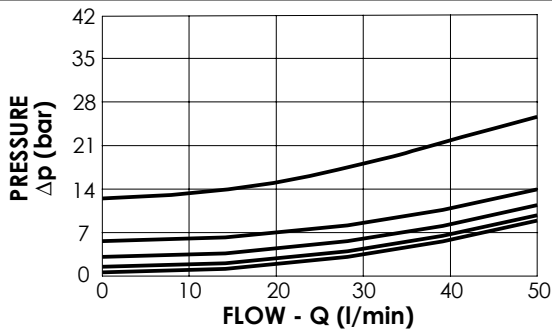

NOTES

Installation torque:	45 - 50 Nm
Seal kit:	RA700081

ORDERING CODES

Quick code	Description	Cracking pressure (bar)	
CD000099	CDVN-050-PSNR-FN-S08-N000	0.35	
CD000024	CDVN-050-PSNR-FN-S08-N001	1	
CD000039	CDVN-050-PSNR-FN-S08-N003	3	
CD000269	CDVN-050-PSNR-FN-S08-N006	6	
CD000070	CDVN-050-PSNR-FN-S08-N013	13	