

COIL

COIL SERIES M7

DEUTSCH DT04-2P-L
CLASS H

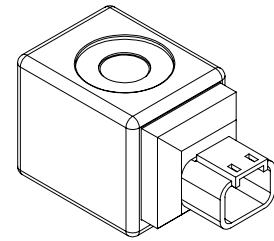
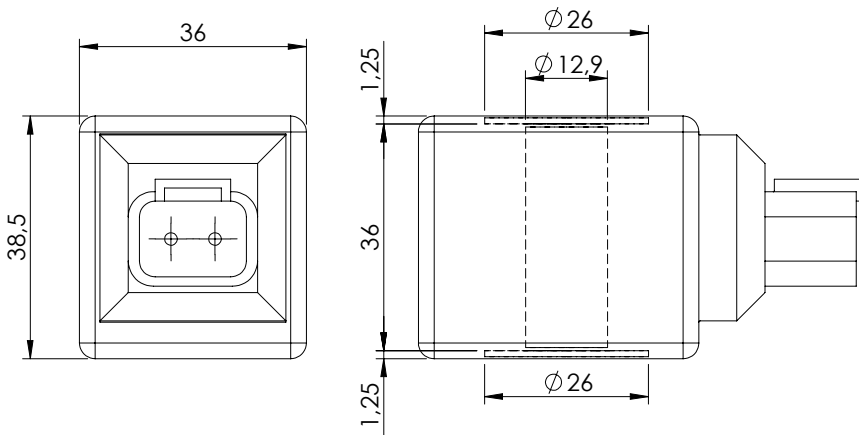
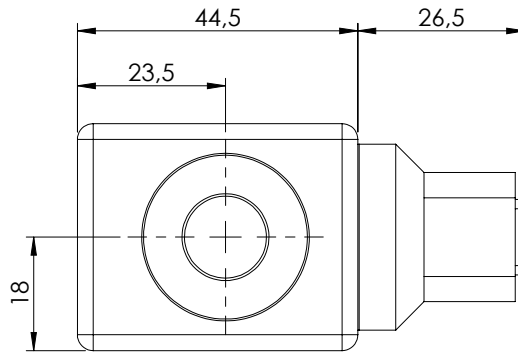

SPECIFICATIONS

Heat insulation class H	180°C
Ambient temperature	-30 + 60°C
Inlet voltage	±10% tol.
Insulation class IP69K with all seals properly mounted	
Weight:	0,18 kg

NOTES

- Equipped with bi-directional diode.
- ED 100% in the functional range area.
- Do not exceed the functional range.
- For applications with working range close to graph limit please contact AFT sales network.
- The seals supplied with the valve must be properly mounted.
- Please refer to catalogue technical chapter for more info.

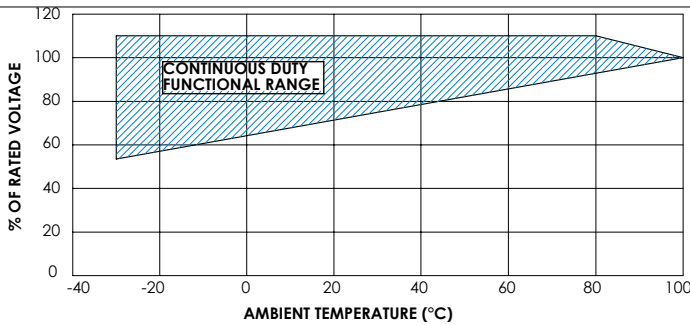

ORDERING CODES

Quick code	Description	Connector type	Voltage (V)	Resistance (Ω) ±7%	Power (w)	Current (A)
AB000001	Coil M7 DT 12V CLASS H	DT04-2P-L	12 DC	7,2	20	1,67
AB000008	Coil M7 DT 24V CLASS H	DT04-2P-L	24 DC	28,8	20	0,83