

HOOK LOADERS

**MBPN-150-ZLNR**

REGENERATIVE  
WITH ELECTRIC BY-PASS

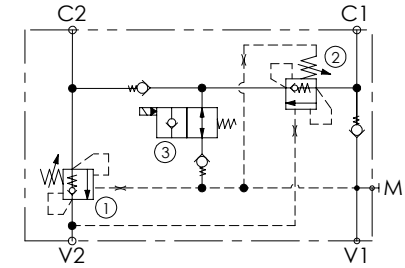
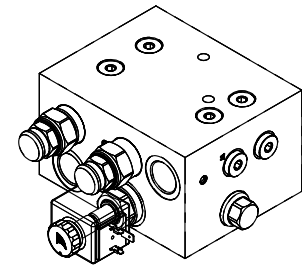
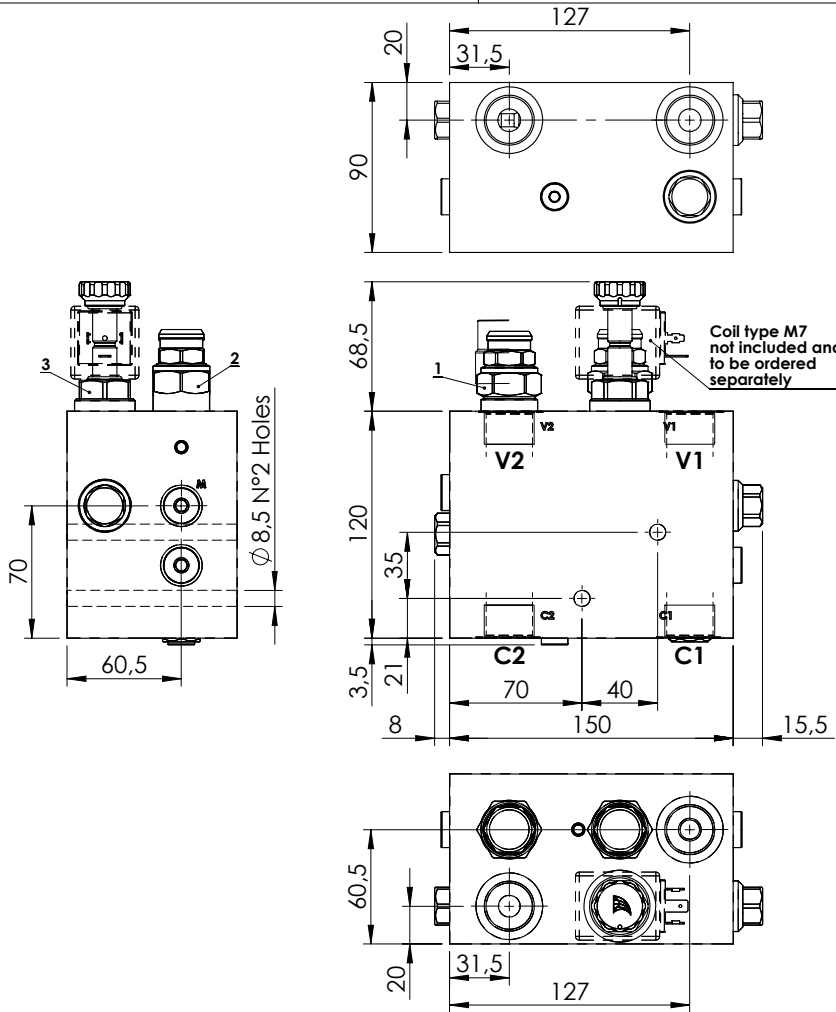

**SPECIFICATIONS**

Max. operating pressure:	350 bar
Rated flow:	150 l/min
Manifold:	Aluminium
Weight:	4,92 kg
Coil type:	M7

**SEALING CAP**

Ordering code:  
ST000012



**NOTES**

Setting: at least 1.3 times the load induced pressure

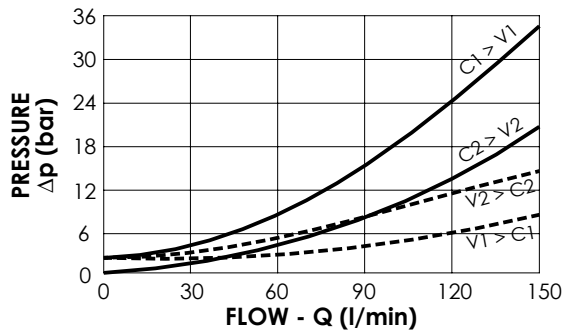

**ORDERING CODES**

Quick code	Description	Pilot ratio	Main ports size	Standard setting (bar, Q=5 l/min)	Adjust. range (bar)	Pressure increase (bar/turn)
MB000919	MBPN-150-ZLNR-04-G34-N210	4:1	C1,C2,V1,V2: G3/4" M: G1/4"	350	100-350	104