

BDEZ-005-LLSI

PROPORTIONAL
PRESSURE REDUCING
PILOT MANIFOLD

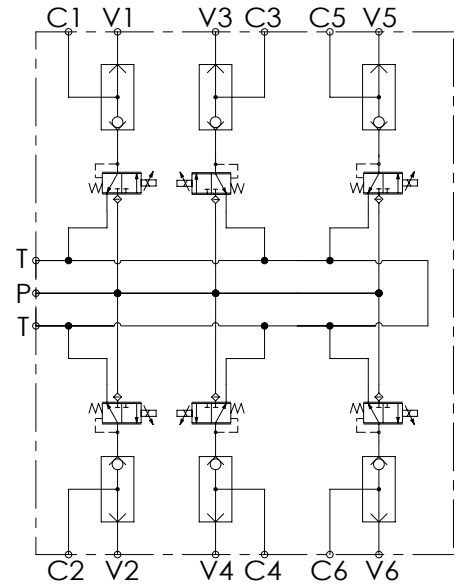
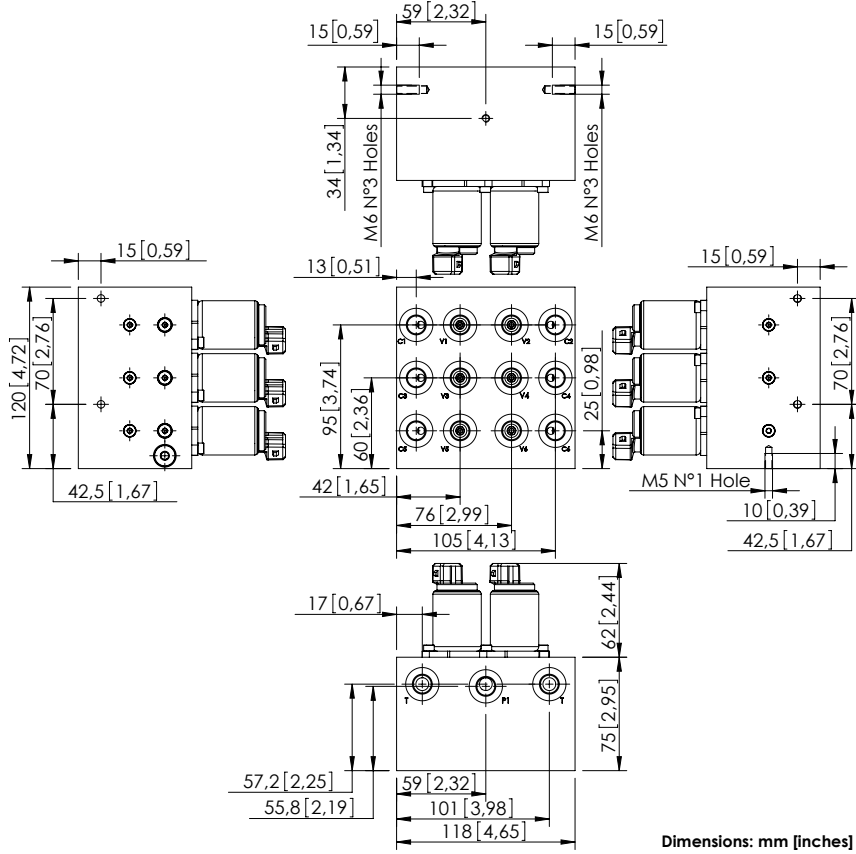

SPECIFICATIONS

Max. operating pressure:	50 bar (700 psi)
Max. operating pressure on port T:	30 bar (400 psi)
Rated flow:	5 l/min (1.3 gpm)
Manifold:	Aluminium
Weight:	3,8 kg (8,3 lbs)
Contamination class to ISO 4406:	See technical spec.
MTTFd:	150 years

NOTES

CURVES

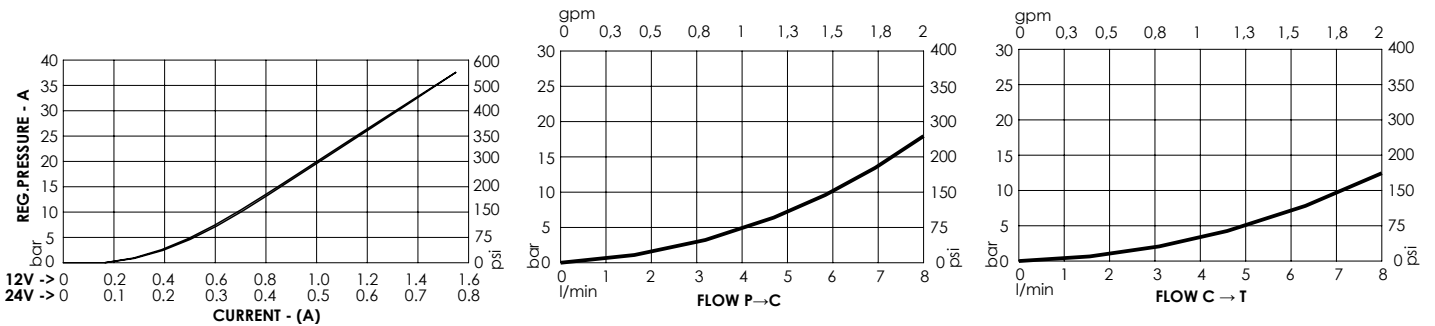

ORDERING CODES

Quick code	Description	Ports	Regulated pressure range	Voltage	Connector type
BD000084	BDEZ-005-LLSI-06-G14-N050-NBAJ	C, V, P, T: G 1/4"	0-20 bar (0-300 psi)	12V DC	AMP JUNIOR
BD000202	BDEZ-005-LLSI-06-G14-N050-NAAJ	C, V, P, T: G 1/4"	0-20 bar (0-300 psi)	24V DC	AMP JUNIOR