

UNLOADING VALVE

MFTS-150-EFCE

SOLENOID OPERATED

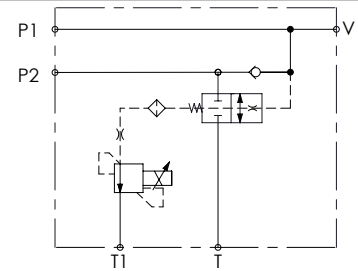
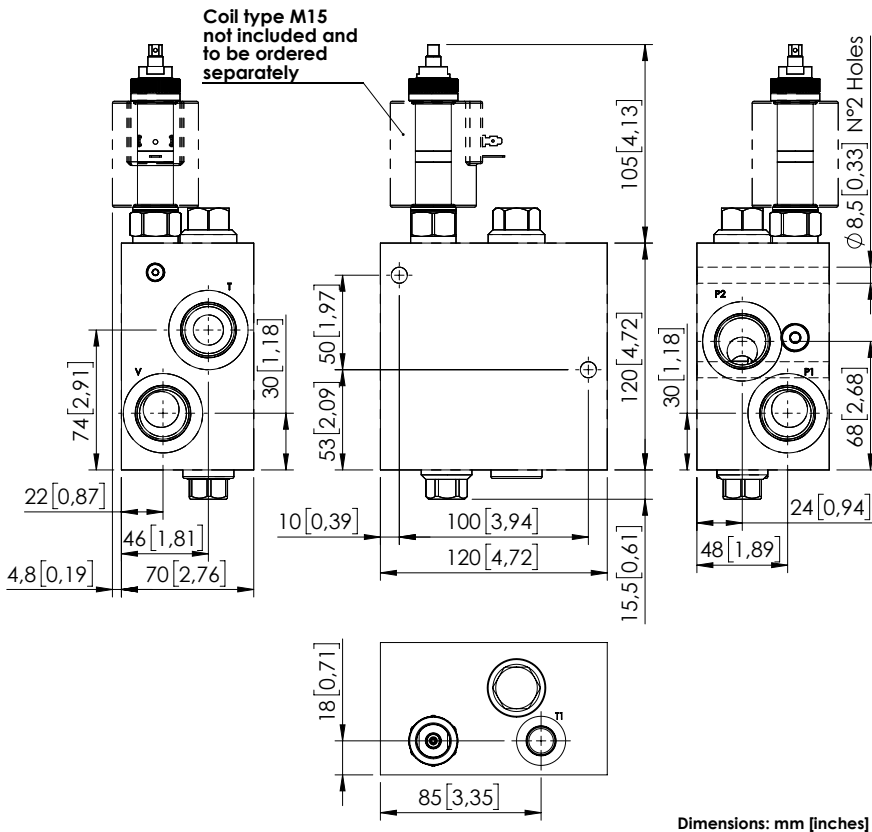

SPECIFICATIONS

Max. operating pressure:	350 bar (5000 psi)
Rated flow:	150 l/min (40 gpm)
Manifold:	Steel
Weight:	7,2 kg (15,9 lbs)
Coil type:	M15
Contamination class to ISO 4406:	See technical spec.
MTF _a :	150 years

NOTES

See chapter 18.00.000 for coil.

CURVES

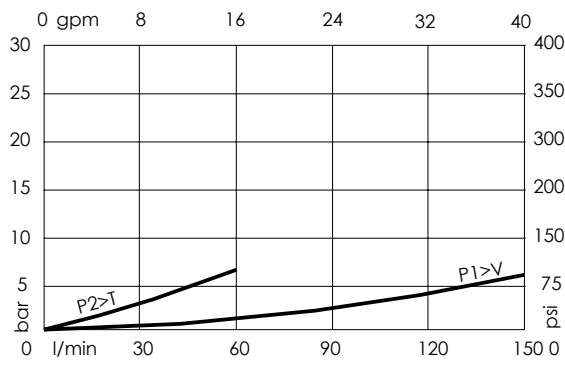

ORDERING CODES

Quick code	Description	Ports	Standard setting	Adjustment range
MF000345	MFTS-150-EFCE-NP-U11-N350	V,P1,P2,T: 1" 1/16-12 UNF T1: 9/16-18 UNF	30 bar (400 psi)	25-340 bar (350-4900 psi)