

UNLOADING VALVE

MFTS-200-DHAN

**SOLENOID OPERATED
UNLOADING VALVE
WITH RELIEF**

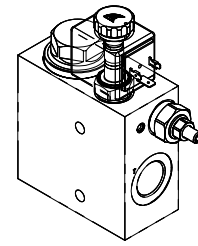
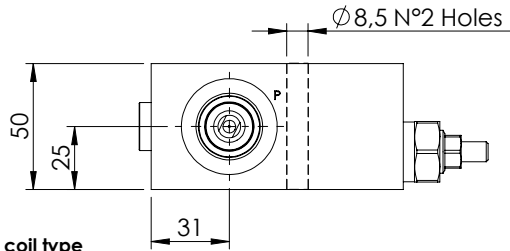

M7 coil type
to be ordered
separately

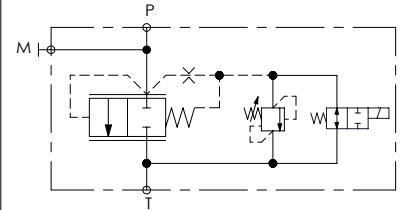
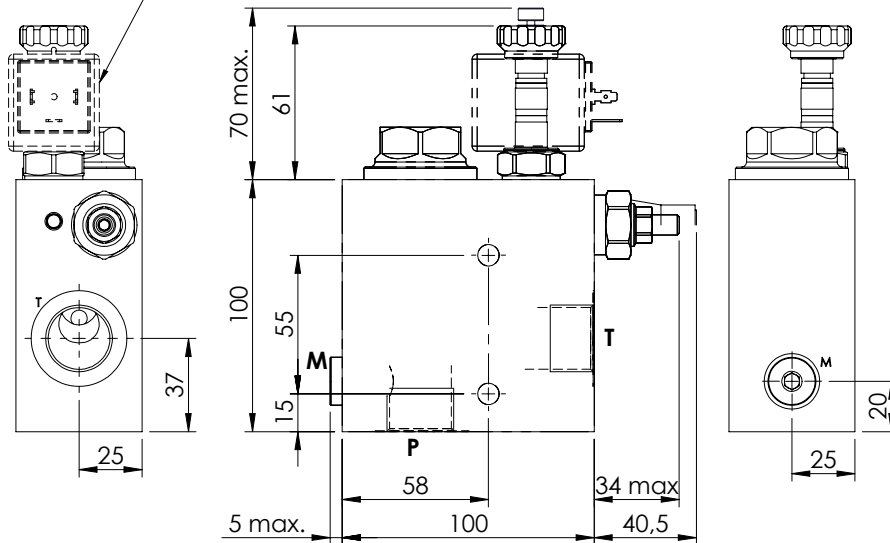

SPECIFICATIONS

Max. operating pressure:	250 bar
Rated flow:	200 l/min
Manifold:	Aluminium
Weight:	1,69 kg
Coil type:	M7

SEALING CAP

Ordering code:
AT000020

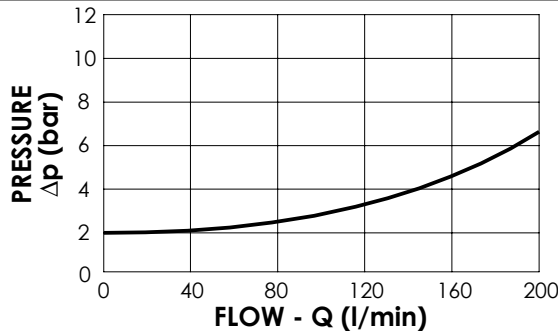

NOTES

Internal leakage: 80 cc/min
Available in steel version for 350 bar
maximum operating pressure
See chapter 18.00.000 for coil.

OPTIONS



Standard



Push style
override

ORDERING CODES

Quick code	Description	Ports size	Standard setting (bar, Q=5 l/min)	Adjust. range (bar)	Pressure increase (bar/turn)	Options
MF000038	MFTS-200-DHAN-NP-G34-N250	P,T:G 3/4" M:G 1/4"	200	140-350	142	Standard
MF000044	MFTS-200-DHAE-NP-G34-N250	P,T:G 3/4" M:G 1/4"	200	140-350	142	Push style override