

CHECK AND METERING VALVE

**MLST-100-ALGR**

IN LINE VERSION  
RIGHT VERSION

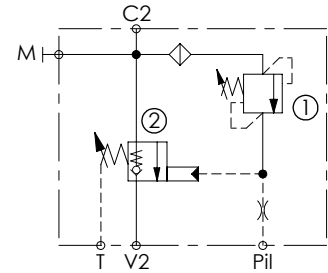
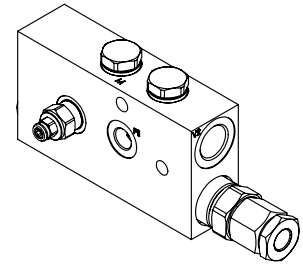
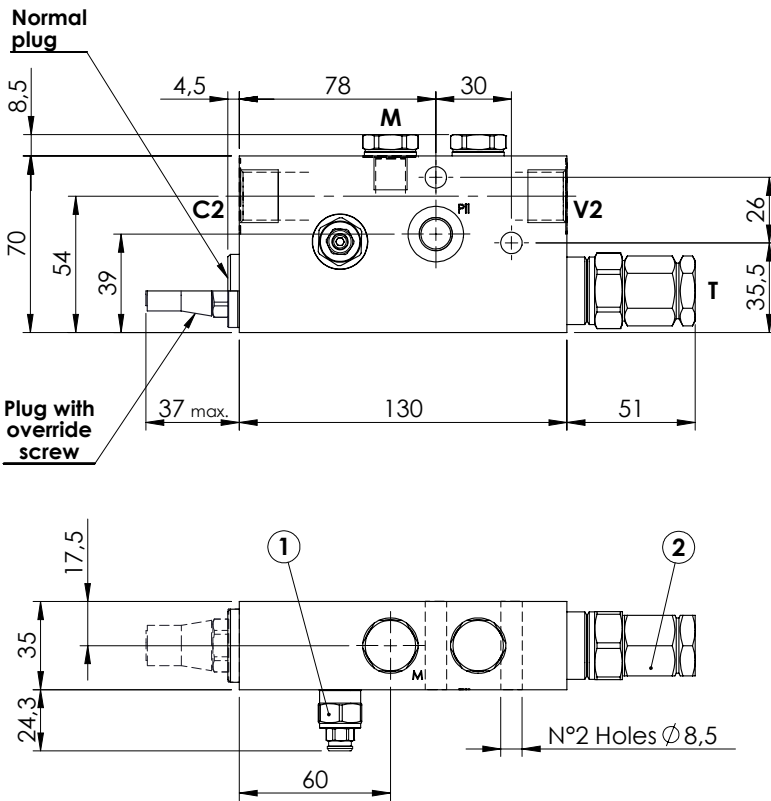

**SPECIFICATIONS**

Max. operating pressure:	420 bar
Rated flow:	100 l/min
Manifold:	Steel
Weight:	2,39 kg

**NOTES**

When correctly adjusted for the specific excavator installation, these valves meet the requirement of ISO 8643

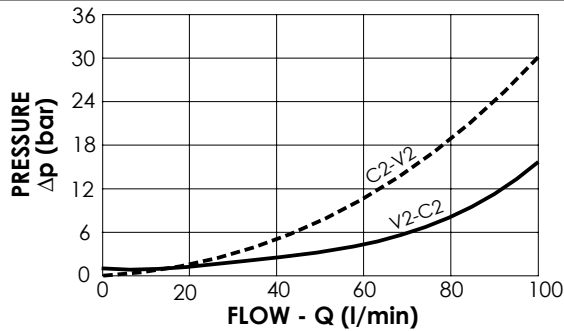

Plug with override screw

Normal plug

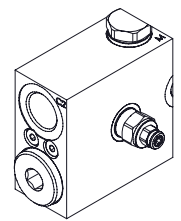
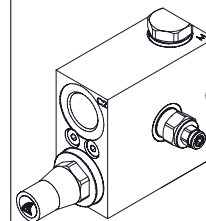

**ORDERING CODES**

Quick code	Description	Main ports size	Plug with override screw	Standard setting (bar)	Adjust. range (bar)	Pressure increase (bar/turn)
ML000134	MLST-100-ALGR-00-G12-N420	V2,C2: G 1/2" Pil, T, M: G 1/4"	No	① 350 Q=5 l/min ② 7.5 Crack. pr.	① 150-420 ② 3-15	① 236 ② 7
ML000147	MLST-100-ALGR-00-G12-E420	V2,C2: G 1/2" Pil, T, M: G 1/4"	Yes	① 350 Q=5 l/min ② 7.5 Crack. pr.	① 150-420 ② 3-15	① 236 ② 7
ML000135	MLST-100-ALGR-00-J12-N420	V2,C2: JIS 1/2" Pil, T, M: JIS 1/4"	No	① 350 Q=5 l/min ② 7.5 Crack. pr.	① 150-420 ② 3-15	① 236 ② 7
ML000148	MLST-100-ALGR-00-J12-E420	V2,C2: JIS 1/2" Pil, T, M: JIS 1/4"	Yes	① 350 Q=5 l/min ② 7.5 Crack. pr.	① 150-420 ② 3-15	① 236 ② 7