

RELIEF VALVE

CPLN-500-PHNA

PILOTED OPERATED
SPOOL TYPE

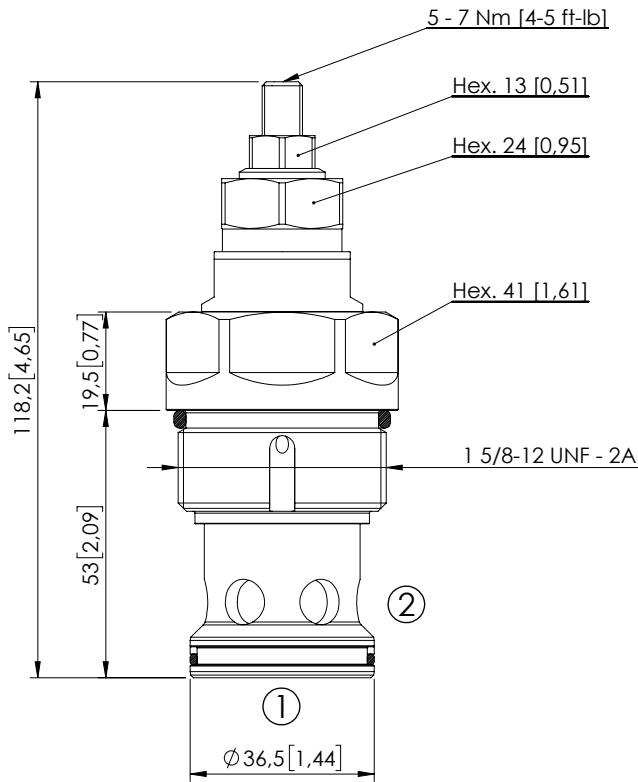

Dimensions: mm [inches]

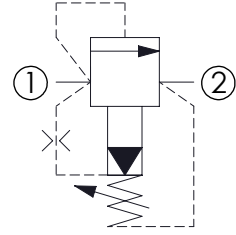

SPECIFICATIONS

Max. operating pressure:	350 bar (5000 psi)
Rated flow:	500 l/min (132 gpm)
Cavity:	SAE-20-2N
Weight:	0,7 kg (1,54 lbs)
Contamination class to ISO 4406:	See technical spec.
Seal kit:	RA900085
Installation torque:	230 - 250 Nm (170 - 184 ft-lb)
MTF _d :	150 years
Max. int. leakage:	400 cm ³ /min (@46 cSt) 24,4 in ³ /min (@46 cSt)

NOTES

SEALING CAP



Ordering code:
AT000020

CURVES

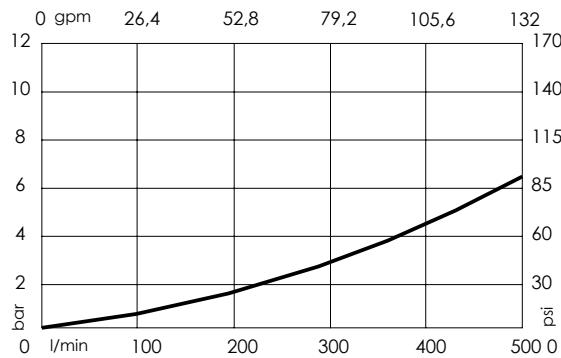

ORDERING CODES

Quick code	Description	Standard setting (cracking pressure)	Adjustment range	Pressure increase
CP000407	CPLN-500-PHNA-SN-S20-N350	350 bar (5000 psi)	140-350 bar (2000-5000 psi)	142 bar/turn (2000 psi/turn)
CP000408	CPLN-500-PHNA-SN-S20-N200	200 bar (2900 psi)	90-210 bar (1300-3000 psi)	87 bar/turn (1200 psi/turn)
CP000409	CPLN-500-PHNA-SN-S20-N100	100 bar (1400 psi)	35-110 bar (500-1600 psi)	47 bar/turn (650 psi/turn)