

RELIEF VALVE

# CPLN-090-DHGA

DIRECT ACTING  
STABILIZED PISTON

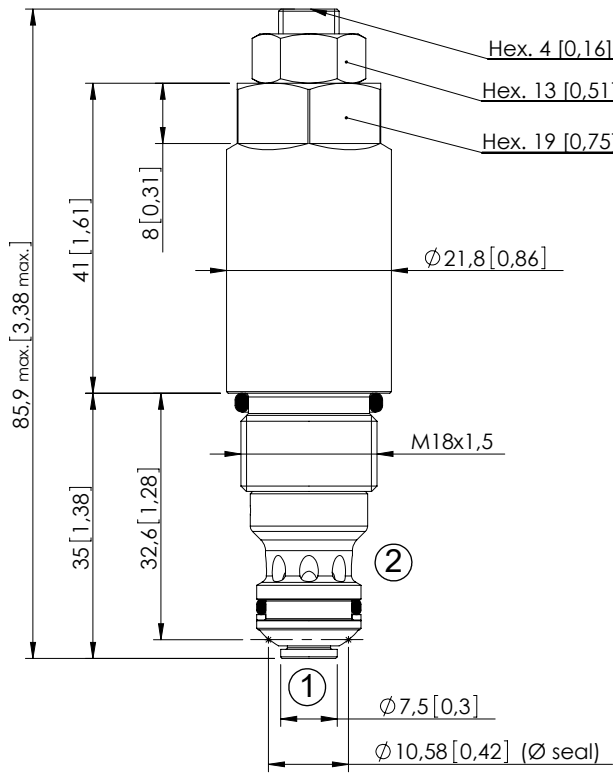

Dimensions: mm [inches]

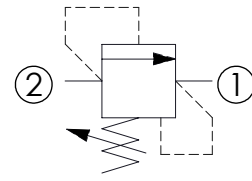

## SPECIFICATIONS

Max. operating pressure:	380 bar (5000 psi)
Rated flow:	90 l/min (24 gpm)
Cavity:	VP000249
Weight:	0,15 kg (0,33 lbs)
Contamination class to ISO 4406:	See technical spec.
Seal kit:	RC900249
Installation torque:	45 - 50 Nm (33 - 37 ft-lb)
MTF <sub>d</sub> :	150 years

## NOTES

## CURVES

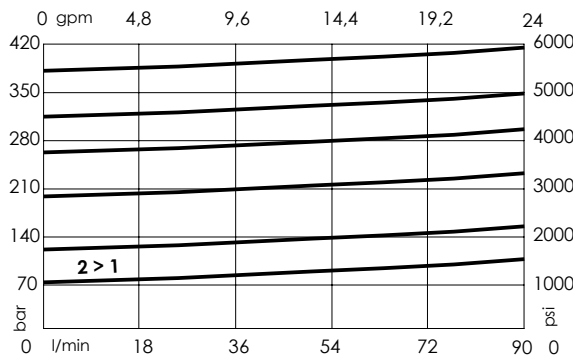

## ORDERING CODES

Quick code	Description	Standard setting (cracking pressure)	Adjustment range	Pressure increase
CP000105	CPLN-090-DHGA-HN-249-N380	380 bar (5400 psi)	320-380 bar (4600-5500 psi)	101 bar/turn (1500 psi/turn)
CP000101	CPLN-090-DHGA-HN-249-N320	320 bar (4500 psi)	270-320 bar (3900-4600 psi)	67 bar/turn (950 psi/turn)
CP000104	CPLN-090-DHGA-HN-249-N270	270 bar (3800 psi)	200-270 bar (2900-3900 psi)	44 bar/turn (650 psi/turn)
CP000103	CPLN-090-DHGA-HN-249-N200	200 bar (2900 psi)	120-200 bar (1700-2900) psi	30 bar/turn (400 psi/turn)
CP000102	CPLN-090-DHGA-HN-249-N120	120 bar (1700 psi)	70-120 bar (1000-1700 psi)	18 bar/turn (250 psi/turn)
CP000120	CPLN-090-DHGA-HN-249-N070	70 bar (1000 psi)	10-70 bar (150-1000 psi)	8 bar/turn (100 psi/turn)