

### SPECIFICATIONS

Max. operating pressure:	350 bar (5000 psi)
Max. operating pressure to PR:	50 bar (725 psi)
Max. operating pressure to DR:	1,5 bar (21 psi)
Rated flow:	2x200 l/min (52 gpm)
Flow regulated:	1,5 - 300 l/min (0,4 - 79 gpm)
Weight:	14,13 kg (31 lbs)
Manifold:	Steel - Zinc plated
Contamination class to ISO 4406:	See technical spec.
MTFfa:	150 - 1200 years: See technical spec.

### NOTES

- Max back pressure admitted on "DR" line 1,5 bar.
  - For correct operation 8-9 bar must be present in port A. For open centre or low pressure systems a 9 bar check valve should be fitted in port A.
  - Spool switching can be influenced by flexing or stressing the valve body. It is recommended to fit spacers on the mounting bolts between the valve and the mounting surface.
- For other configurations/quick codes not available in this catalogue page please consult factory

### SCHEME

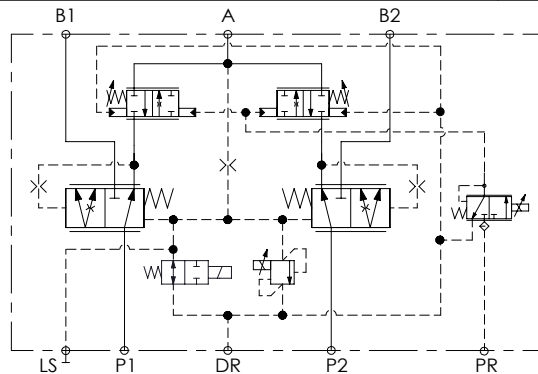

### CURVES

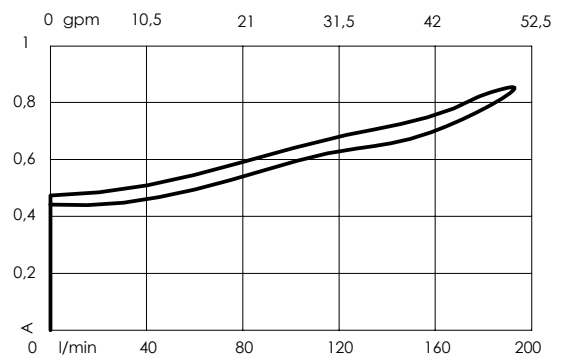
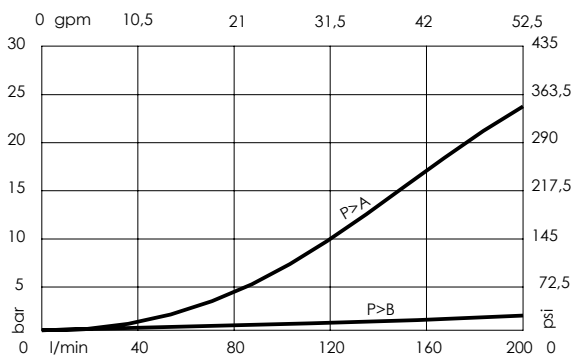

### ORDERING CODES

Quick code	Description	Type of coil	Mail ports size	Setting range
MF000412	MFTT-200-MHAR-30-J10-V350-12V	12V - DT04	P,B: 3/4" JIS A: 1" JIS PR,DR,LS: 1/4" JIS	30- 350 bar (430 - 5000 psi)
MF000413	MFTT-200-MHAR-30-J10-V350-24V	24V - DT04		
MF000172	MFTT-200-MHAR-30-G10-V350-12V	12V - DT04	P,B: G 3/4" A: G 1" PR,DR,LS: G 1/4"	30- 350 bar (430 - 5000 psi)
MF000173	MFTT-200-MHAR-30-G10-V350-24V	24V - DT04		