

SPECIFICATIONS

Max. operating pressure:	350 bar (5000 psi)
Max. operating pressure to PR:	50 bar (725 psi)
Max. operating pressure to DR:	1,5 bar (21 psi)
Rated flow:	200 l/min (52,5 gpm)
Flow regulated:	1,5 - 160 l/min (0,4 - 42 gpm)
Weight:	10,12 kg (22 lbs)
Manifold:	Steel - Zinc plated
Contamination class to ISO 4406:	See technical spec.
MTF _a :	150 years

NOTES

- Max back pressure admitted on "DR" line 1,5 bar.
- For correct operation 8-9 bar must be present in port A. For open centre or low pressure systems a 9 bar check valve should be fitted in port A.
- Spool switching can be influenced by flexing or stressing the valve body. It is recommended to fit spacers on the mounting bolts between the valve and the mounting surface.

SCHEME

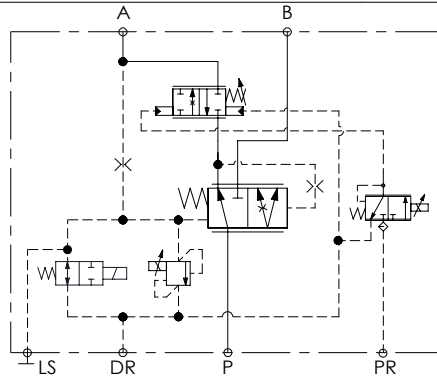

CURVES

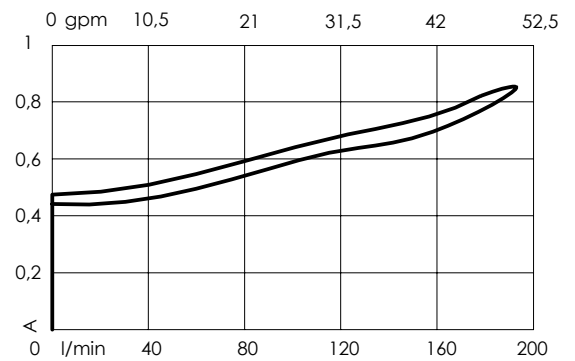
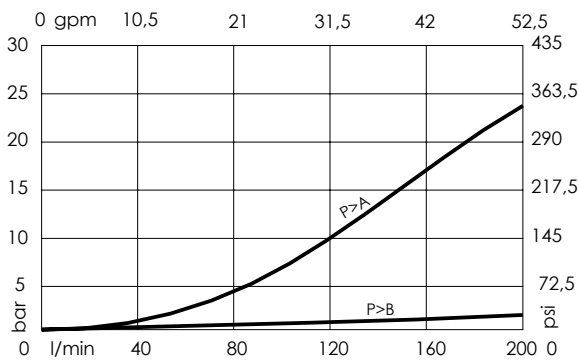

ORDERING CODES

Quick code	Description	Type of coil	Mail ports size	Setting range
MF000410	MFPT-200-MHAR-16-J10-V350-12V	12V - DT04	P,B: 3/4" JIS A: 1" JIS	30- 350 bar (430 - 5000 psi)
MF000411	MFPT-200-MHAR-16-J10-V350-24V	24V - DT04	PR,DR,LS: 1/4" JIS	
MF000170	MFPT-200-MHAR-16-G10-V350-24V	12V - DT04	P,B: G 3/4" A: G 1"	30- 350 bar (430 - 5000 psi)
MF000171	MFPT-200-MHAR-16-G10-V350-24V	24V - DT04	PR,DR,LS: G 1/4"	