

## SPECIFICATIONS

Max. operating pressure:	350 bar (5000 psi)
Max. operating pressure to PR:	50 bar (725 psi)
Max. operating pressure to DR:	1,5 bar (21 psi)
Rated flow:	100 l/min (26 gpm)
Regulated flow:	1,5 - 85 l/min 0,4-22 gpm
Weight:	8,37 kg (21,6 lbs)
Manifold:	Steel - Zinc plated
Contamination class to ISO 4406:	See technical spec.
MTF <sub>d</sub> :	150 - 1200 years: See technical spec.

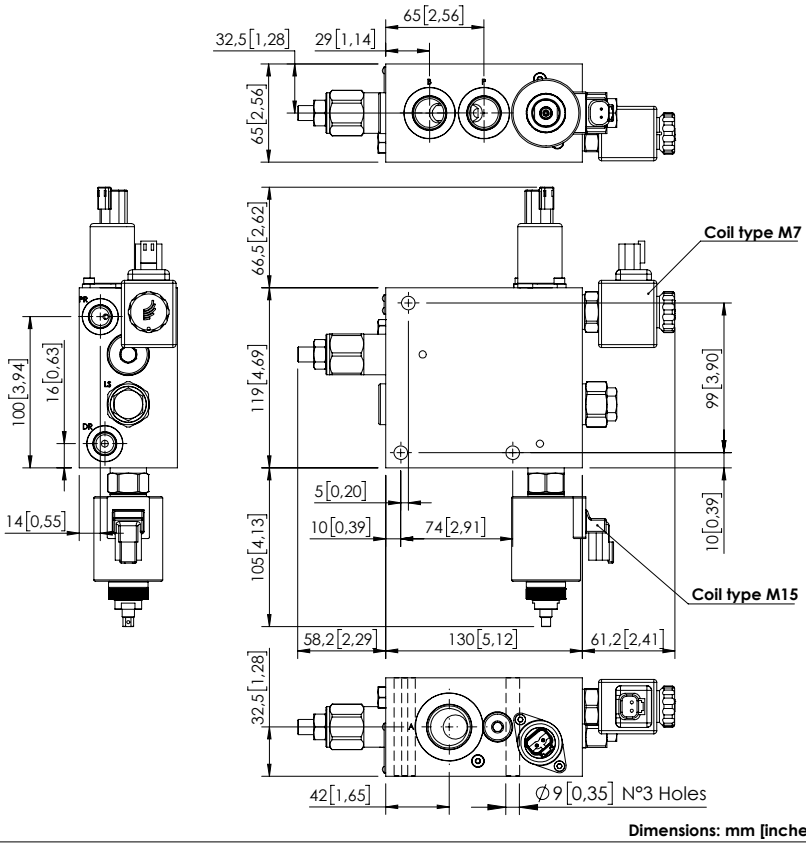

## NOTES

- Max back pressure admitted on "DR" line 1,5 bar.
  - For correct operation 8-9 bar must be present in port A. For open centre or low pressure systems a 9 bar check valve should be fitted in port A .
  - Spool switching can be influenced by flexing or stressing the valve body. It is recommended to fit spacers on the mounting bolts between the valve and the mounting surface.
- For other configurations/quick codes not available in this catalogue page please consult factory

## SCHEME

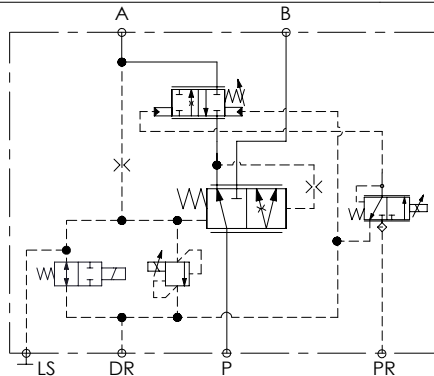

## CURVES

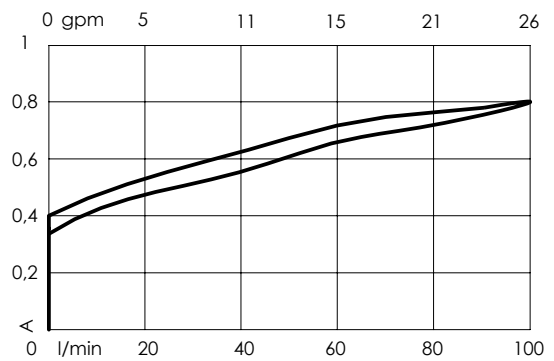
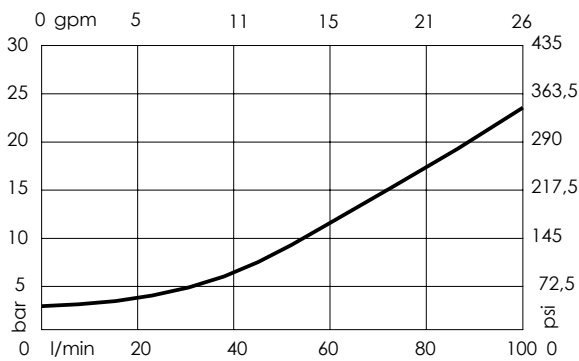

## ORDERING CODES

Quick code	Description	Type of coil	Mail ports size	Setting range
MF000406	MFPT-100-MHAR-85-J34-V350-12V	12V - DT04	P,B: 1/2" JIS A: 3/4" JIS PR,DR,LS: 1/4" JIS	30- 350 bar (430 - 5000 psi)
MF000407	MFPT-100-MHAR-85-J34-V350-24V	24V - DT04		
MF000166	MFPT-100-MHAR-85-G34-V350-12V	12V - DT04	P,B: G 1/2" A: G 3/4" PR,DR,LS: G 1/4"	30- 350 bar (430 - 5000 psi)
MF000167	MFPT-100-MHAR-85-G34-V350-24V	24V - DT04		