

# MBSP-150-ZLSE

SINGLE ACTING  
RELIEF COMPENSATED

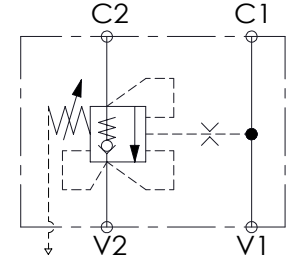
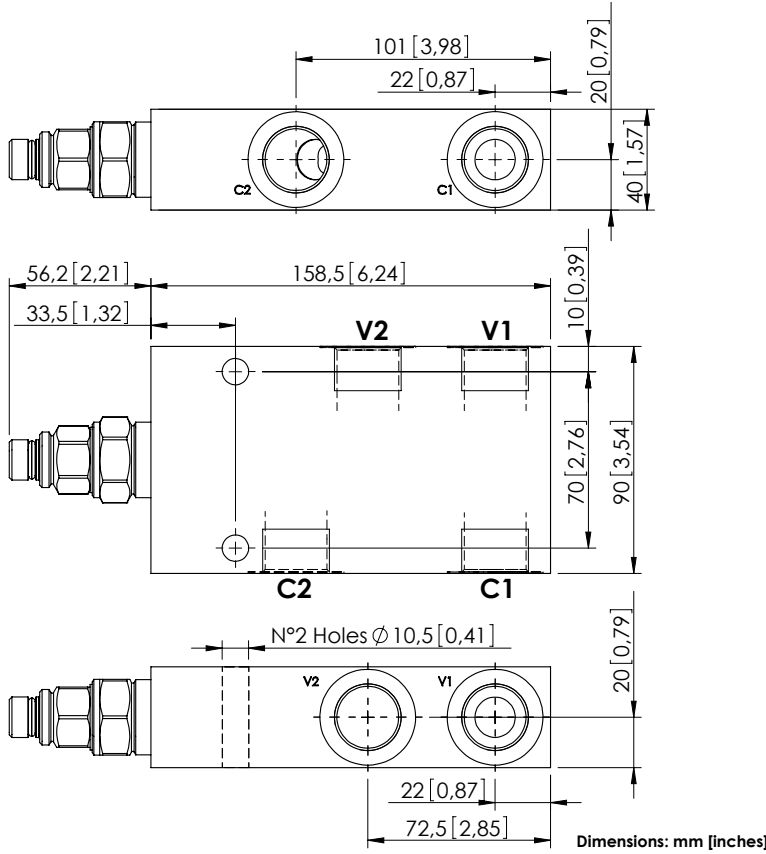

## SPECIFICATIONS

Max. operating pressure:	350 bar (5000 psi)
Rated flow:	150 l/min (40 gpm)
Weight:	Aluminium: 1,6 kg (3,53 lbs) Steel: 3,9 kg (8,6 lbs)
Contamination class to ISO 4406:	See technical spec.
MTTFd:	150 - 1200 years: See technical spec.

## NOTES

Setting: at least 1.3 times the load induced pressure.  
For other configurations/quick codes not available in this catalogue page please consult factory

## CURVES

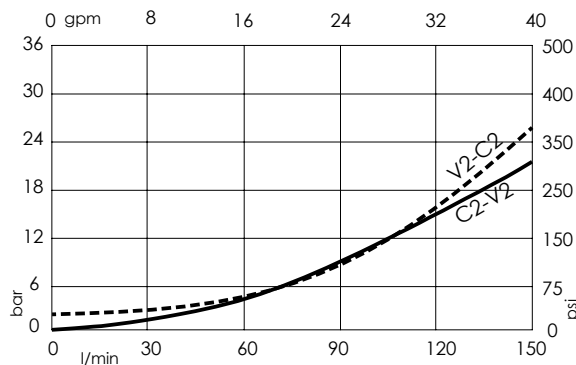

## ORDERING CODES

Quick code	Description	Pilot ratio	Manifold material	Main ports size	Standard setting (Q=5 l/min)	Adjustment range	Pressure increase
MB000500	MBSP-150-ZLSE-08-G34-N350	8:1	Aluminium	V1, V2: G3/4" C1, C2: G3/4"	350 bar (5000 psi)	100-350 bar (1400-5000 psi)	83 bar/turn (1200 psi/turn)
MB000501	MBSP-150-ZLSE-08-G34-N200	8:1	Aluminium	V1, V2: G3/4" C1, C2: G3/4"	200 bar (2900 psi)	60-210 bar (850-3000 psi)	47 bar/turn (700 psi/turn)
MB000502	MBSP-150-ALDE-08-G34-N350	8:1	Steel	V1, V2: G3/4" C1, C2: G3/4"	350 bar (5000 psi)	100-350 bar (1400-5000 psi)	83 bar/turn (1200 psi/turn)
MB000503	MBSP-150-ALDE-08-G34-N200	8:1	Steel	V1, V2: G3/4" C1, C2: G3/4"	200 bar (2900 psi)	60-210 bar (850-3000 psi)	47 bar/turn (700 psi/turn)
MB000504	MBSP-150-ZLSE-04-G34-N350	4:1	Aluminium	V1, V2: G3/4" C1, C2: G3/4"	350 bar (5000 psi)	100-350 bar (1400-5000 psi)	104 bar/turn (1500 psi/turn)
MB000505	MBSP-150-ZLSE-04-G34-N200	4:1	Aluminium	V1, V2: G3/4" C1, C2: G3/4"	200 bar (2900 psi)	60-210 bar (850-3000 psi)	56 bar/turn (800 psi/turn)
MB000506	MBSP-150-ALDE-04-G34-N350	4:1	Steel	V1, V2: G3/4" C1, C2: G3/4"	350 bar (5000 psi)	100-350 bar (1400-5000 psi)	104 bar/turn (1500 psi/turn)
MB000507	MBSP-150-ALDE-04-G34-N200	4:1	Steel	V1, V2: G3/4" C1, C2: G3/4"	200 bar (2900 psi)	60-210 bar (850-3000 psi)	56 bar/turn (800 psi/turn)