

# MBDN-060-AMSF

OVERCENTRE  
WITH BRAKE RELEASE

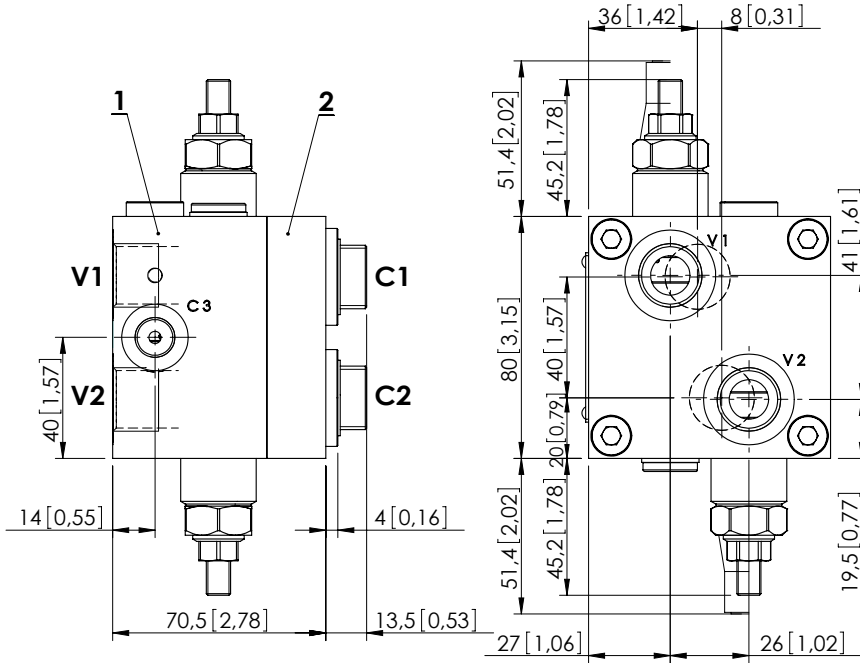

Dimensions: mm [inches]

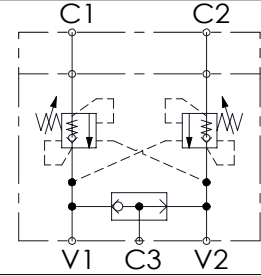

## SPECIFICATIONS

Max. operating pressure:	350 bar (5000 psi)
Rated flow:	60 l/min (16 gpm)
Manifold:	Steel
Weight:	3,46 kg (7,58 lbs)
Contamination class to ISO 4406:	See technical spec.
MTF <sub>a</sub> :	150 - 1200 years: See technical spec.

## NOTES

Setting: at least 1.3 times the load induced pressure.  
 Designed for SAM HYDRAULIK BR motors.  
 Valve composed by:  
 1.MB000619  
 2.MP000034  
 For other configurations/quick codes not available in this catalogue page please consult factory

## SEALING CAP



Ordering code:  
AT000020

## CURVES

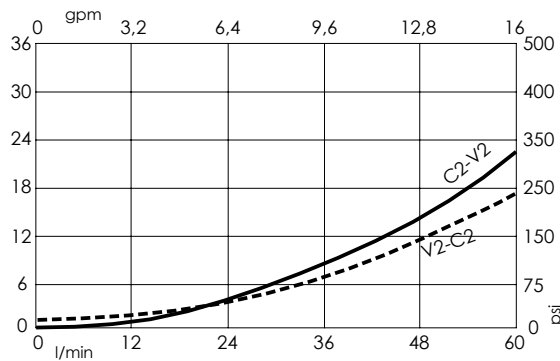

## ORDERING CODES

Quick code	Description	Pilot ratio	Main ports size	Standard setting Q=5 l/min (1,3 gpm)	Adjustment range	Pressure increase
MB000317	MBDN-060-AMSF-04-G12-N200-SH BR	4,2:1	V1,V2: G 1/2" C1,C2: Sam Hydraulik flange C3: G 1/4"	200 bar (2900 psi)	60-210 bar (850-3000 psi)	62 bar/turn (900 psi/turn)