

MBSN-060-AASV

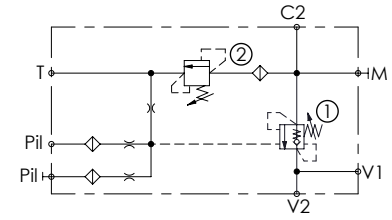
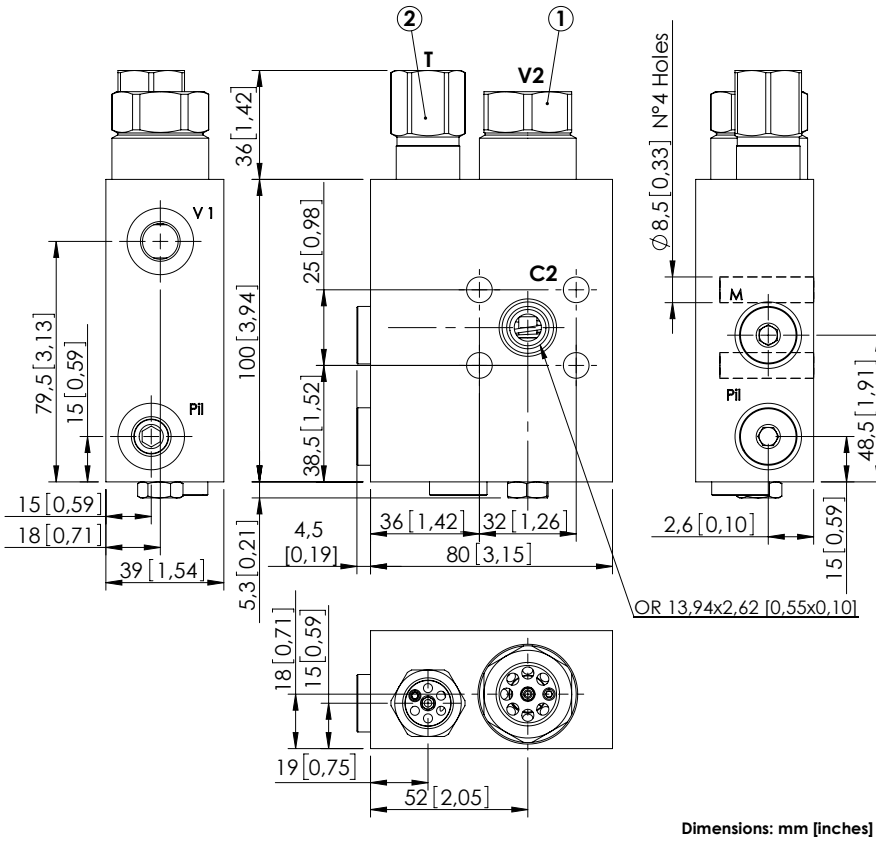

SPECIFICATIONS

Max. operating pressure:	500 bar (7200 psi)
Rated flow:	60 l/min (16 gpm)
Manifold:	Steel
Weight:	2.38 kg (5.3 lbs)
Contamination class to ISO 4406:	See technical spec.
MTTFa:	150 - 1200 years: See technical spec.

NOTES

Setting: at least 1.3 times the load induced pressure.

Operative pilot ratio: 2.5:1

For other configurations/quick codes not available in this catalogue page please consult factory

CURVES

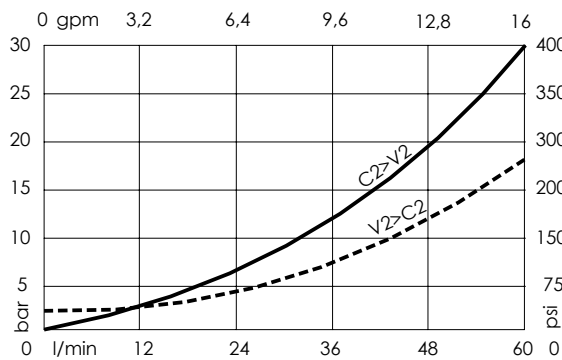

ORDERING CODES

Quick code	Description	Pilot ratio	Ports	Standard setting Q=5 l/min (1.3 gpm)	Adjustment range	Pressure increase bar/turn (psi/turn)
MB000088	MBSN-060-AASV-02-G12-N500	7:1	V1, P11: G 1/4" C2: Ø9 T: G 3/8" V2: G 1/2" M: G 1/8"	① 420 bar (6000 psi) ② 280 bar (4000 psi)	① 200-450 bar (2900-6500 psi) ② 100-450 bar (1500-6500 psi)	① 366 (5300) ② 102 (1500)