

KPLN-080-DPNA

DIRECT ACTING
STABILIZED PISTON

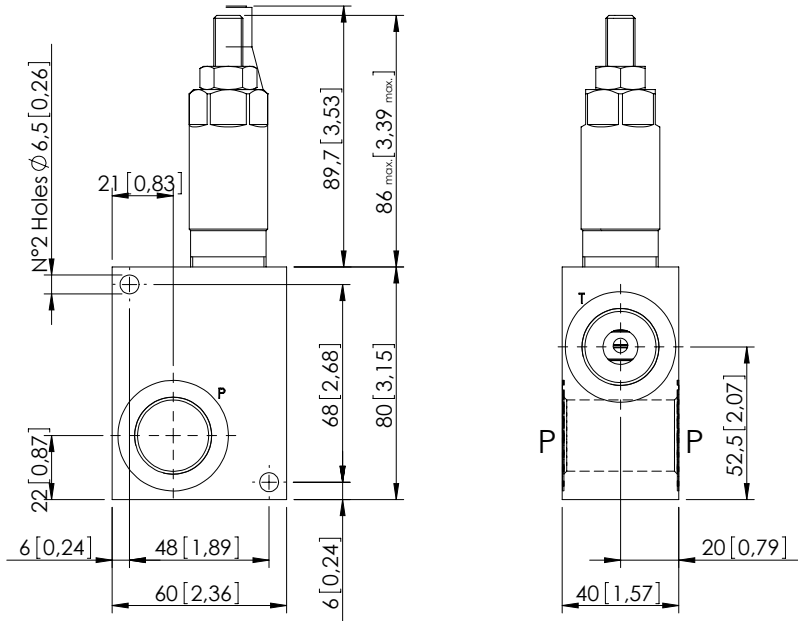

Dimensions: mm [inches]

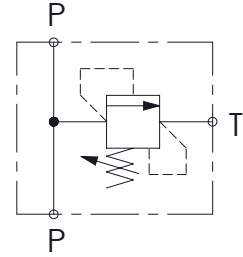

SPECIFICATIONS

Max. operating pressure:	350 bar (5000 psi)
Rated flow:	80 l/min (21 gpm)
Manifold:	Aluminium
Weight:	0,68 kg (1,5 lbs)
Contamination class to ISO 4406:	See technical spec.
MTTf:	150 - 1200 years: See technical spec.

NOTES

Codes available with steel manifold.

For other configurations/quick codes not available in this catalogue page please consult factory

SEALING CAP

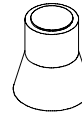

Ordering code:
AT000021

CURVES

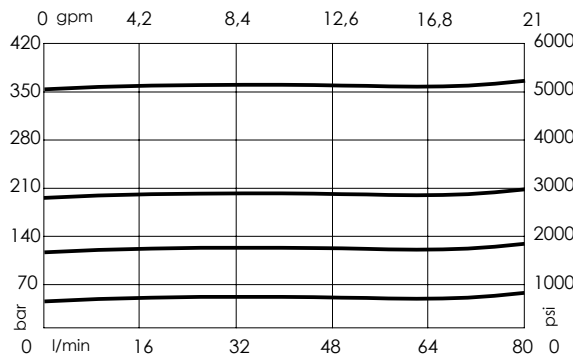

ORDERING CODES

Quick code	Description	Main ports size	Standard setting Q=5 l/min (1,3 gpm)	Adjustment range	Pressure increase
KP000018	KPLN-080-DPNA-HN-G34-N350	P,T : G 3/4"	350 bar (5000 psi)	100-350 bar (1400-5000 psi)	42 bar/turn (600 psi/turn)
KP000070	KPLN-080-DPNA-HN-G34-N200	P,T : G 3/4"	200 bar (2900 psi)	60-210 bar (900-3000 psi)	24 bar/turn (350 psi/turn)
KP000069	KPLN-080-DPNA-HN-G34-N100	P,T : G 3/4"	100 bar (1400 psi)	25-100 bar (350-1400 psi)	13 bar/turn (200 psi/turn)
KP000098	KPLN-080-DPNA-HN-G34-N050	P,T : G 3/4"	50 bar (700 psi)	5-50 bar (100-700 psi)	9 bar/turn (150 psi/turn)
KP000016	KPLN-080-DPNA-HN-G12-N350	P,T : G 1/2"	350 bar (5000 psi)	100-350 bar (1400-5000 psi)	42 bar/turn (600 psi/turn)
KP000090	KPLN-080-DPNA-HN-G12-N200	P,T : G 1/2"	200 bar (2900 psi)	60-210 bar (900-3000 psi)	24 bar/turn (350 psi/turn)
KP000091	KPLN-080-DPNA-HN-G12-N100	P,T : G 1/2"	100 bar (1400 psi)	25-100 bar (350-1400 psi)	13 bar/turn (200 psi/turn)
KP000099	KPLN-080-DPNA-HN-G12-N050	P,T : G 1/2"	50 bar (700 psi)	5-50 bar (100-700 psi)	9 bar/turn (150 psi/turn)