

CPRL-140-PNNR

PILOT OPERATED
SPOOL TYPE

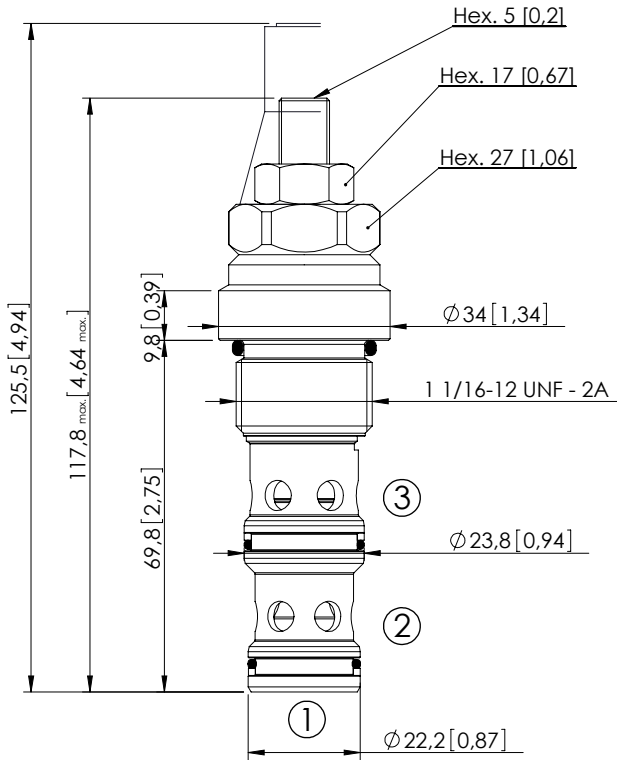

Dimensions: mm [inches]

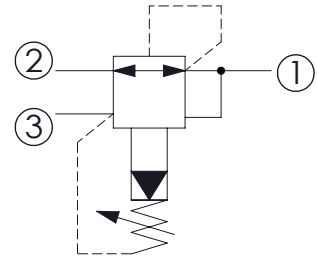

SPECIFICATIONS

Max. operating pressure:	350 bar (5000 psi)
Rated flow:	140 l/min (37 gpm)
Cavity:	SAE-12-3N
Weight:	0,34 kg (0,75 lbs)
Contamination class to ISO 4406:	See technical spec.
Seal kit:	RA700093
Installation torque:	80 - 95 Nm (59 - 70 ft-lb)
MTTF _d :	150 - 1200 years: See technical spec.

NOTES

For other configurations/quick codes not available in this catalogue page please consult factory

OPTIONS

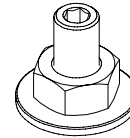

Adjustment with Screw

SEALING CAP



Ordering code:
AT000022

CURVES

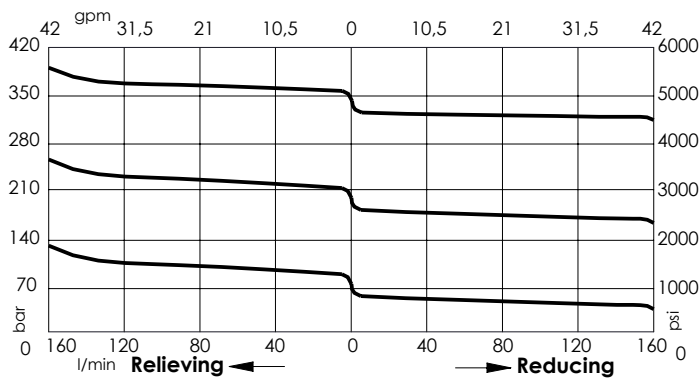

ORDERING CODES

Quick code	Description	Standard setting	Adjustment range	Pressure increase	Options
CR000020	CPRL-140-PNNR-HN-S12-N350	300 bar (4300 psi)	140-350 bar (2000-5000 psi)	114 bar/turn (1600 psi/turn)	Adjustment with Screw
CR000019	CPRL-140-PNNR-HN-S12-N200	200 bar (2900 psi)	70-250 bar (1000-3600 psi)	69 bar/turn (1000 psi/turn)	Adjustment with Screw
CR000018	CPRL-140-PNNR-HN-S12-N100	100 bar (1400 psi)	10-140 bar (150-2000 psi)	37 bar/turn (550 psi/turn)	Adjustment with Screw