

CPLT-030-DHNA

DIRECT ACTING COMPENSATED
STABILIZED PISTON
HARDENED SEAT

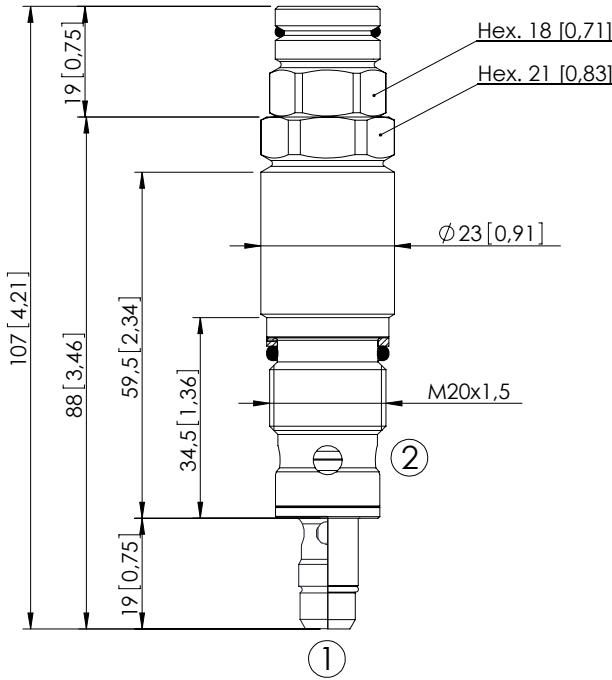

Dimensions: mm [inches]

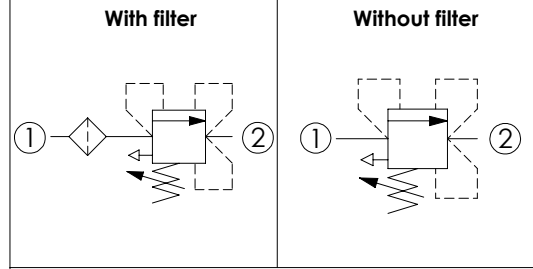

SPECIFICATIONS

Max. operating pressure:	420 bar (6000 psi)
Max. operating pressure on T:	350 bar (5000 psi)
Rated flow:	30 l/min (8 gpm)
Cavity:	VP000008
Weight:	0,2 kg (0,44 lbs)
Contamination class to ISO 4406:	See technical spec.
Seal kit:	RC700008
Installation torque:	45 - 50 Nm (33 - 37 ft-lb)
MTTF _d :	150 - 1200 years: See technical spec.
Filtration:	300 micron

NOTES

For other configurations/quick codes not available in this catalogue page please consult factory

CURVES

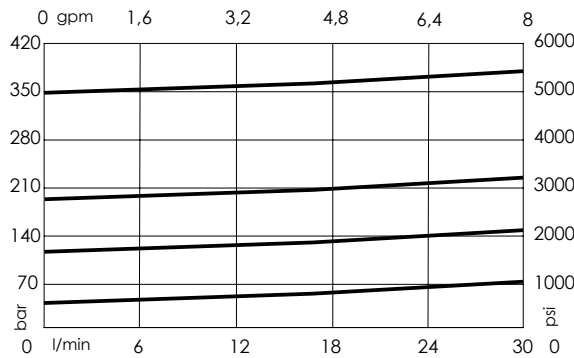

ORDERING CODES

Quick code	Description	Standard setting Q=5 l/min (1,3 gpm)	Adjustment range	Pressure increase	Option
CP000410	CPLT-030-DHNA-HF-008-N420	350 bar (5000 psi)	250-420 bar (3600-6000 psi)	104 bar/turn (1500 psi/turn)	With Filter
CP000095	CPLT-030-DHNA-HN-008-N350	350 bar (5000 psi)	100-350 bar (1400-5000 psi)	91 bar/turn (1300 psi/turn)	Without Filter
CP000096	CPLT-030-DHNA-HN-008-N200	200 bar (2900 psi)	50-210 bar (700-3000 psi)	42 bar/turn (600 psi/turn)	Without Filter
CP000097	CPLT-030-DHNA-HN-008-N100	100 bar (1400 psi)	30-100 bar (400-1400 psi)	20 bar/turn (300 psi/turn)	Without Filter
CP000098	CPLT-030-DHNA-HN-008-N050	50 bar (700 psi)	10-50 bar (150-700 psi)	10 bar/turn (150 psi/turn)	Without Filter