

CFSN-090-BPSR

FLOW REGULATOR
SPARE PART

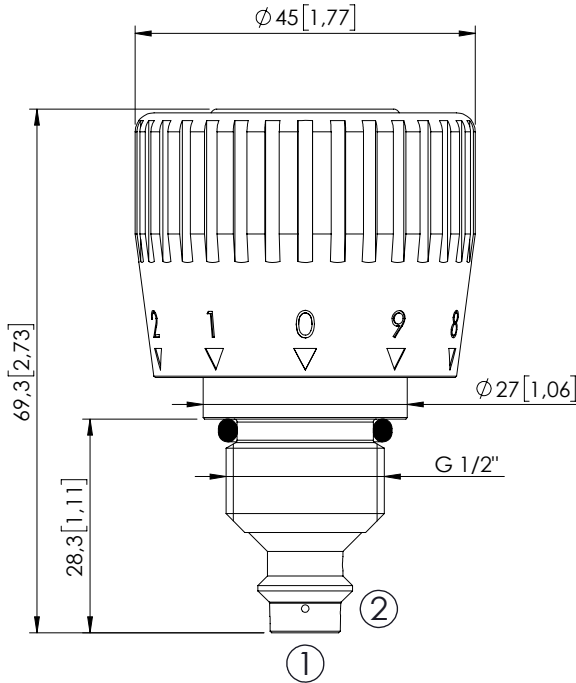
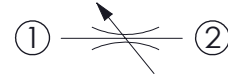

Dimensions: mm [inches]

SPECIFICATIONS

Max. operating pressure:	350 bar (5000 psi)
Rated flow:	80 l/min (21 gpm)
Cavity:	VP000132
Weight:	0,25 kg 0,55 lbs)
Installation torque:	130 - 140 Nm (96 - 103 ft-lb)
Seal kit:	RC700132
Contamination class to ISO 4406:	See technical spec.
MTF _d :	150 - 1200 years: See technical spec.

NOTES

Components we be supplied partially disassembled.
Contact AFT sales network for assembling instruction
For other configurations/quick codes not available in this catalogue page please consult factory

OPTIONS

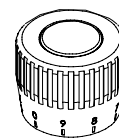

Graduated handknob
for flow regulation
under pressure

ORDERING CODES

Quick code	Description	Flow range adjustment	Options
CF000237	CFSN-090-BMSR-06-132-N350	0-6 l/min (0-2 gpm)	Graduated handknob
CF000238	CFSN-090-BMSR-12-132-N350	0-12 l/min (0-3 gpm)	Graduated handknob
CF000239	CFSN-090-BMSR-25-132-N350	0-25 l/min (7 gpm)	Graduated handknob
CF000240	CFSN-090-BMSR-32-132-N350	0-32 l/min (0-8 gpm)	Graduated handknob
CF000392	CFSN-090-BMSR-50-132-N350	0-50 l/min (0-13 gpm)	Graduated handknob
CF000242	CFSN-090-BMSR-63-132-N350	0-63 l/min (0-17 gpm)	Graduated handknob
CF000243	CFSN-090-BMSR-70-132-N350	0-70 l/min (0-19 gpm)	Graduated handknob
CF000244	CFSN-090-BMSR-80-132-N350	0-80 l/min (0-21 gpm)	Graduated handknob