

SOLENOID OPERATED CARTRIDGE

CECS-030-SEFN-64

DIRECT ACTING
SPOOL TYPE

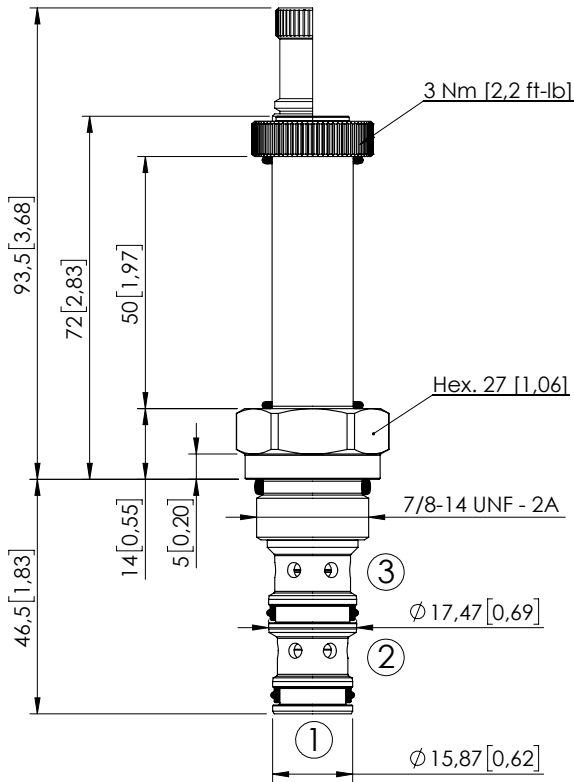

Dimensions: mm [inches]

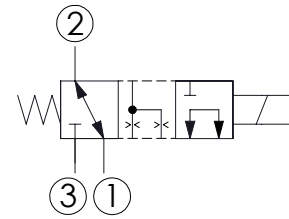

SPECIFICATIONS

Max. operating pressure:	350 bar (5000 psi)
Rated flow:	30 l/min (8 gpm)
Cavity:	SAE-10-3N
Weight:	0,2 kg (0,44 lbs)
Min. voltage required:	90% of nominal
Coil type:	M16 type
Ambient temperature:	-20/+50 °C (-4/+122 °F)
Contamination class to ISO 4406:	See technical spec.
Seal kit:	RB600092
Installation torque:	55 - 62 Nm (41 - 46 ft-lb)
MTF _d :	150 - 1200 years: See technical spec.
Leakage:	70 cm ³ /min (@46 cSt) 4,2 in ³ /min (@46 cSt)

NOTES

For other configurations/quick codes not available in this catalogue page please consult factory

OPTIONS

Standard



Knob style override

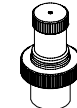

CURVES

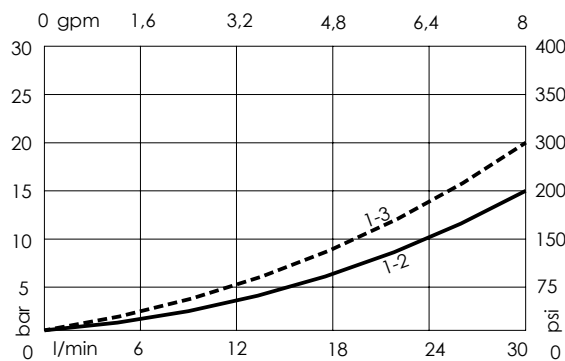

ORDERING CODES

Quick code	Description	Options
CE000991	CECS-030-SEFN-64-S10-N350	Standard
CE000992	CECS-030-SEFE-64-S10-N350	Knob style override