

SOLENOID OPERATED CARTRIDGE

**CECS-030-SEFN-62**

DIRECT ACTING  
SPOOL TYPE

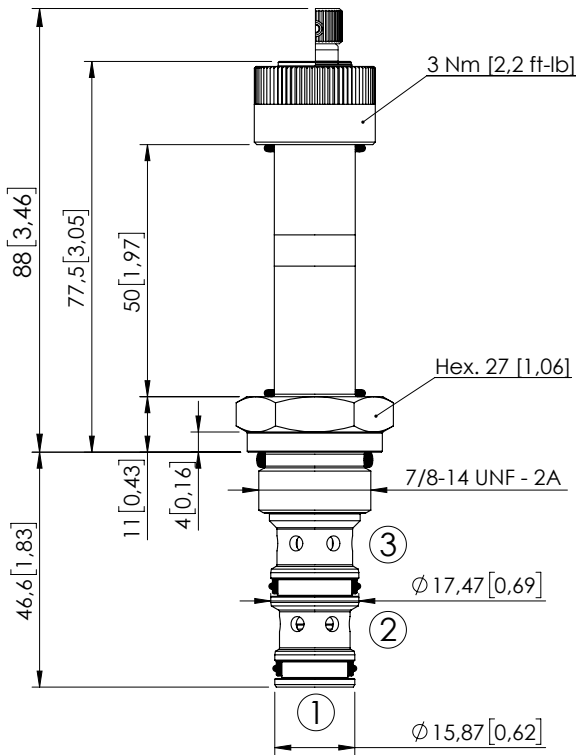

Dimensions: mm [inches]

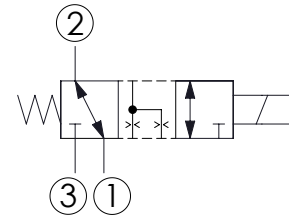

**SPECIFICATIONS**

Max. operating pressure:	350 bar (5000 psi)
Rated flow:	30 l/min (8 gpm)
Cavity:	SAE-10-3N
Weight:	0,26 kg (0,57 lbs)
Min. voltage required:	90% of nominal
Coil type:	M16 type
Ambient temperature:	-20/+50 °C (-4/+122 °F)
Contamination class to ISO 4406:	See technical spec.
Seal kit:	RB600092
Installation torque:	50 - 55 Nm (37 - 41 ft-lb)
MTF <sub>d</sub> :	150 - 1200 years: See technical spec.
Leakage:	70 cm <sup>3</sup> /min (@46 cSt) 4,2 in <sup>3</sup> /min (@46 cSt)

**NOTES**

For other configurations/quick codes not available in this catalogue page please consult factory

**OPTIONS**

Standard



Knob style override

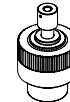

**CURVES**

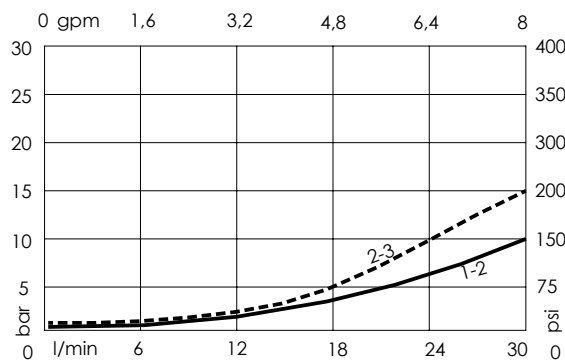

**ORDERING CODES**

Quick code	Description	Options
CE000987	CECS-030-SEFN-62-S10-N350	Standard
CE000988	CECS-030-SEFE-62-S10-N350	Knob style override