

CDPN-030-PSGR

INTEGRAL PILOT
PISTON

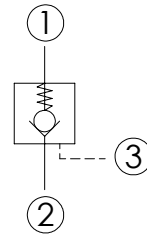
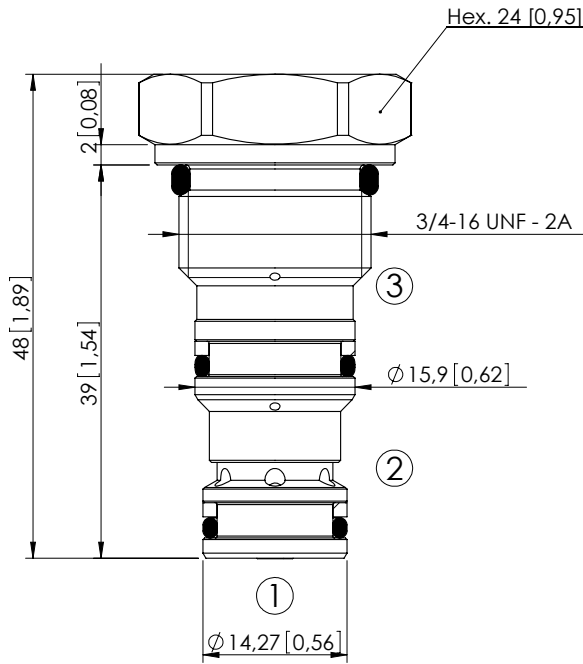

SPECIFICATIONS

Max. operating pressure:	350 bar (5000 psi)
Rated flow:	30 l/min (8 gpm)
Cavity:	SAE-08-3C
Weight:	0,09 kg (0,2 lbs)
Pilot ratio:	3:1
Contamination class to ISO 4406:	See technical spec.
Seal kit:	RA700086
Installation torque:	40 - 45 Nm (30 - 33 ft-lb)
MTTFa:	150 - 1200 years: See technical spec.

Dimensions: mm [inches]

NOTES

For other configurations/quick codes not available in this catalogue page please consult factory

CURVES

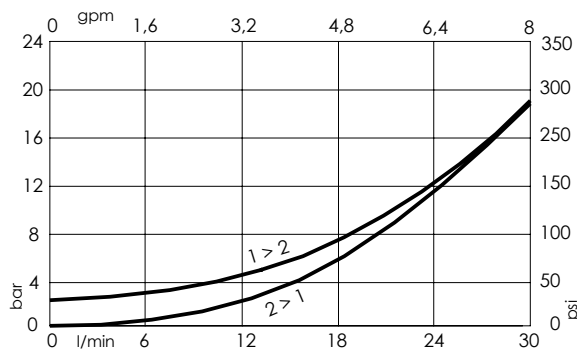

ORDERING CODES

Quick code	Description	Cracking pressure	O-ring on pilot piston
CD000027	CDPN-030-PSGR-03-S08-N002	2 bar (25 psi)	YES
CD000061	CDPN-030-PSGM-03-S08-N002	2 bar (25 psi)	NO