

BDMN-010-LLCS

HYDRAULIC PRESSURE
UNLOADING
3 WAYS

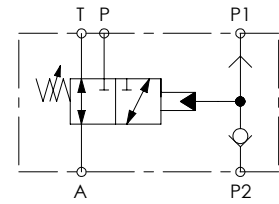
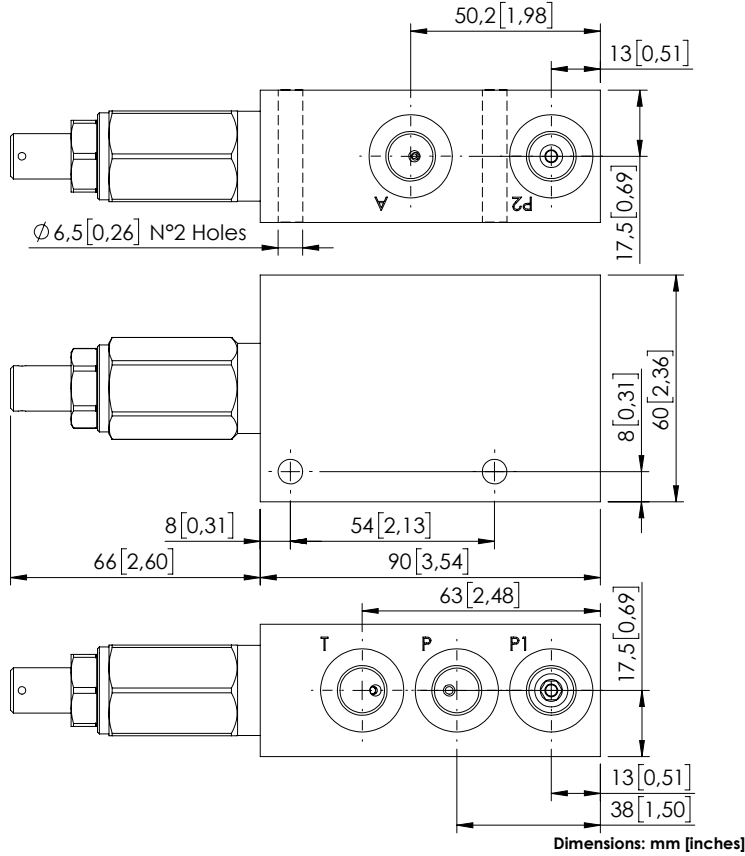

SPECIFICATIONS

Max. operating pressure:	210 bar (3000 psi)
Rated flow:	8 l/min (2 gpm)
Weight:	0,7 kg (1,5 lbs)
Manifold:	Aluminium
Contamination class to ISO 4406:	See technical spec.
MTTFd:	150 - 1200 years: See technical spec.

NOTES

For other configurations/quick codes not available in this catalogue page please consult factory

CURVES

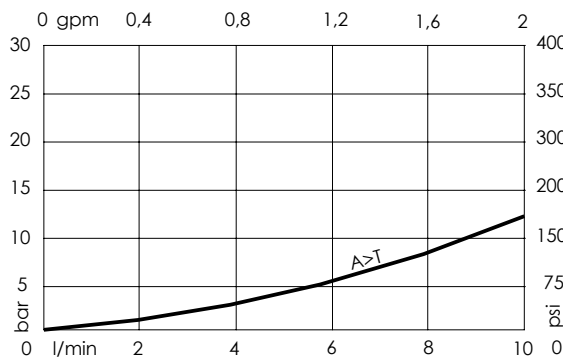

ORDERING CODES

Quick code	Description	Ports	Standard setting Q=5 l/min (1,3 gpm)	Setting range	Pressure increase
BD000104	BDMN-010-LLCS-NP-G14-N210	T,P,P1,A: G 1/4"	5 bar (70 psi)	4-40 bar (60-600 psi)	3 bar/turn (50 psi/turn)