

COIL

COIL SERIES M7

DEUTSCH DT04-2P-V
CLASS H

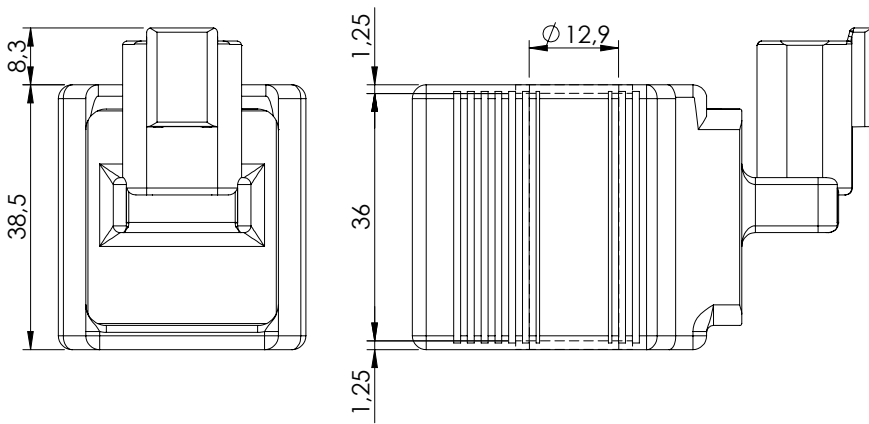
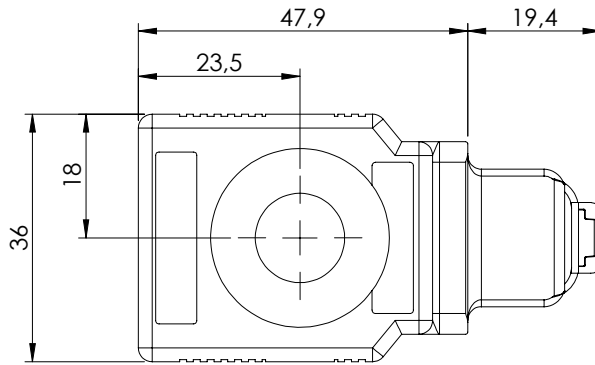
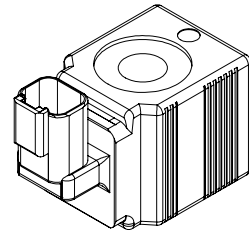

SPECIFICATIONS

Heat insulation class H	180°C
Ambient temperature	-30 + 60°C
Inlet voltage	±10% tol.
Insulation class IP69K with all seals properly mounted	
Weight:	0,18 kg

NOTES

- Equipped with bi-directional diode.
- ED 100% in the functional range area.
- Do not exceed the functional range.
- For applications with working range close to graph limit please contact AFT sales network.
- The seals supplied with the valve must be properly mounted.
- Please refer to catalogue technical chapter for more info.

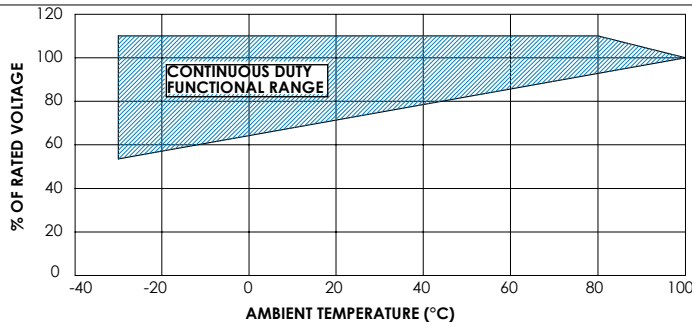

ORDERING CODES

Quick code	Description	Connector type	Voltage (V)	Resistance (Ω) ±7%	Power (w)	Current (A)
AB000022	Coil M7 DTV 12V CLASS H	DT04-2P-V	12 DC	7,2	20	1,67
AB000229	Coil M7 DTV 14V CLASS H	DT04-2P-V	14 DC	9,8	20	1,43
AB000023	Coil M7 DTV 24V CLASS H	DT04-2P-V	24 DC	28,8	20	0,83
AB000024	Coil M7 DTV 26V CLASS H	DT04-2P-V	26 DC	33,8	20	0,77
AB000230	Coil M7 DTV 28V CLASS H	DT04-2P-V	28 DC	39,4	20	0,71